

Charly

95% PRE BUILT
ARF
ALMOST READY TO FLY

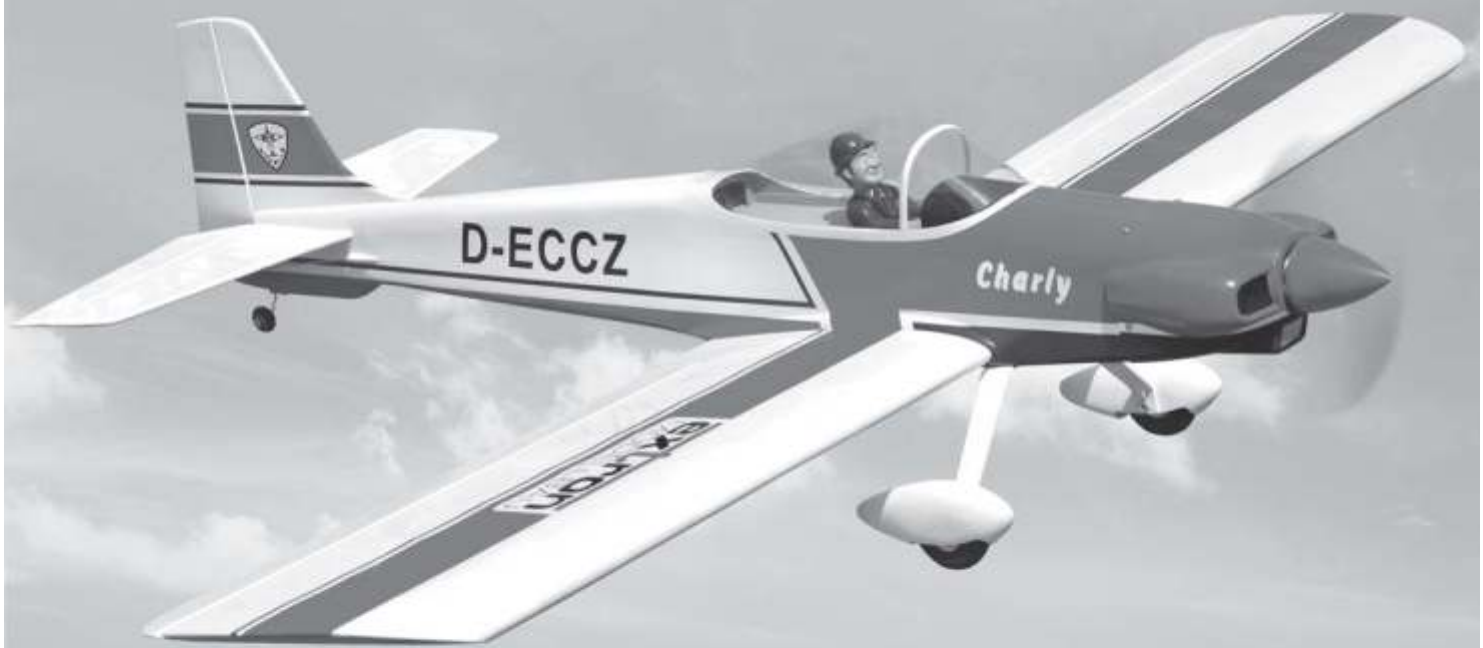

ALL Balsa- PLY WOOD CONSTRUCTION.
COVERED WITH PVC PRINTING

95% ALMOST READY TO FLY

Technische Daten *

Spannweite	1500mm
Länge	1200mm
Flächeninhalt	43.5dm ²
Flächenbelastung	45g/dm ²
Fluggewicht	1900 -2100g
R/C	4 Kanal
Servos	4
Motor	PULSAR 40 / Brushless
Regler	PULSAR 50A
Akku	3500-4500mAh / 11,1-14,8V

* Änderungen und Irrtümer vorbehalten

Specifications *

Wingspan	1500mm
Length	1200mm
Wing Area	43.5dm ²
Wing loading	45g/dm ²
Flying Weight	1900 -2100g
R/C	4 channels
Servos	4
Motor	PULSAR 40 / Brushless
ESC	PULSAR 50A
Akku	3500-4500mAh / 11,1-14,8V

* Subject to change without notice

Dieses ferngesteuerte R/C Flugmodell ist für Anfänger nicht geeignet sondern richtet sich an fortgeschrittene Modellbauer. Trotz sehr hoher Vorfertigung erfordern die Endmontage und der Betrieb des Modells etwas Übung sowie grundlegende Erfahrungen. Wenn Sie unerfahren sind, bitten Sie einen Modellbaukollegen um Hilfe oder fragen Ihren Modellbau-Fachhändler vor Ort. Bevor Sie mit dem Zusammenbau beginnen, prüfen Sie den Inhalt auf Vollständigkeit, Passgenauigkeit bzw. eventuelle Mängel. Für den Zusammenbau benötigen Sie das übliche Werkzeug sowie Klebstoffe wie Sekundenkleber und 5-Minuten Epoxy. Der Lieferumfang kann ggf. abweichen. Das Modell wurde von erfahrenen Mitarbeitern weitgehendst in Handarbeit gefertigt und selbstverständlich vor dem Versand im Werk sorgfältig geprüft. Trotzdem bitten wir Sie zu beachten:

Wir entwickeln und fertigen unsere Modelle zum Fliegen und nicht, um damit einen Scale-Wettbewerb zu gewinnen. Deshalb gilt: Kleine Unregelmäßigkeiten am Modell sind normal und berechtigen nicht zur Reklamation. Ein gewisses Maß an Nacharbeit kann erforderlich sein und ist dem Kunden (= fortgeschrittener Modellbauer) zuzumuten. Das Modell wurde werksseitig mit bedruckter Klebefolie falten- und blasenfrei bespannt. Aufgrund von Temperaturschwankungen während Transport und Lagerung kann es zu mehr oder weniger starker Falten- und Blasenbildung kommen. Dies ist normal und kein Reklamationsgrund. Mit einem Heißluftgebläse (Fön) kann die Folie unter vorsichtiger Wärmeeinwirkung wieder gespannt werden. ACHTUNG: Keinesfalls ein Bügeleisen verwenden. Vielen Dank für Ihr Verständnis.

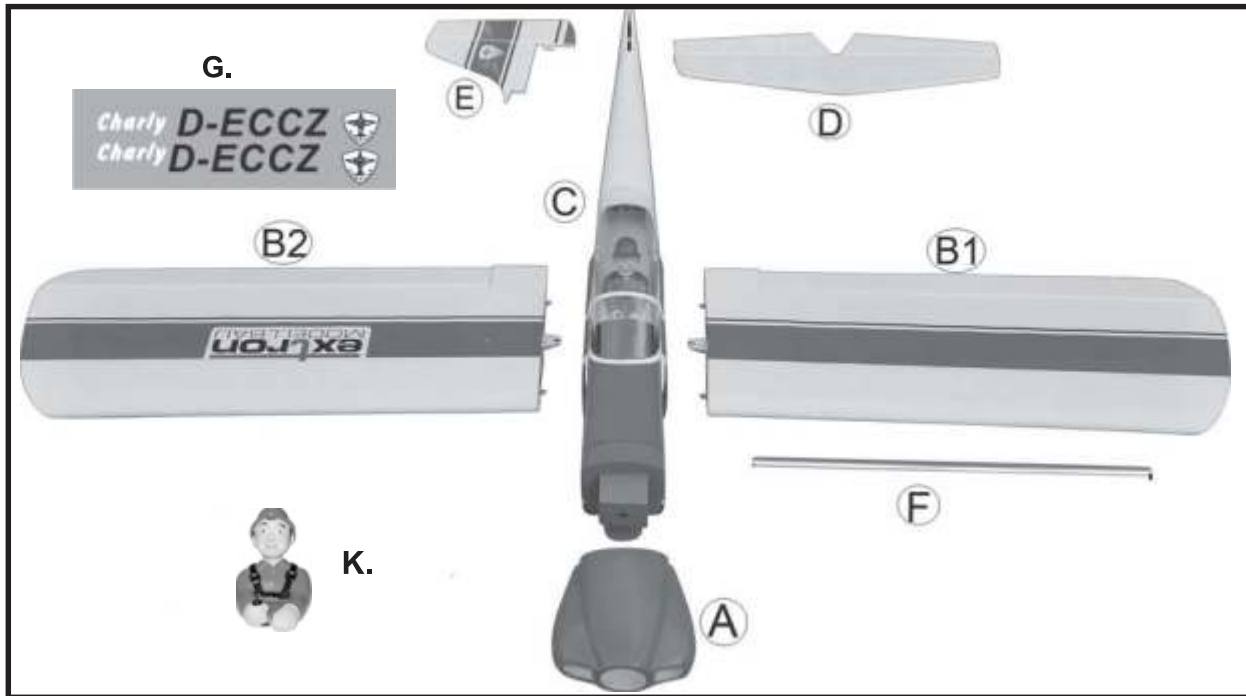

- A. Motorhaube / Cowling.
- B. Tragflächen / Wing panel (B1,B2).
- C. Rumpf / Fuselage.
- D. Höhenleitwerk / Horizontal stabilizer.
- E. Seitenleitwerk / Vertical stabilizer.
- F. Tragflächenrohr / Aluminium wing joiner.
- G. Dekorbogen / Decal sheet.
- K. Pilot

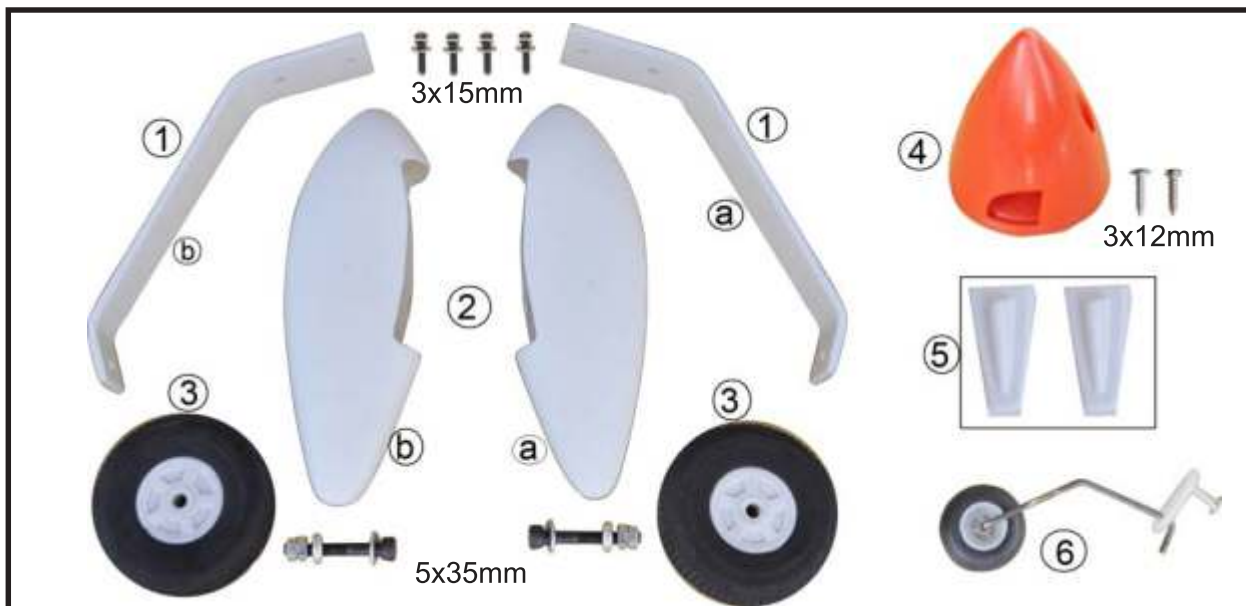

- 1. Hauptfahrwerk / Main landing gear(1a,1b).
- 2. Radschuhe / Wheel pants (2a,2b).
- 3. Räder / Wheels
- 4. Spinner
- 5. Kunststoffteile / Plastic parts
- 6. Heckspornrad / Tail gear set

Sonderzubehör für Charly / Accessories for Charly

Nachstehendes Zubehör wurde von uns ausgiebig erprobt und wird für beste Flugeigenschaften empfohlen. Weitere Informationen und Bestellmöglichkeit unter www.extron.net

These accessories have been extensively tested and are recommended for best flying performance. For more information please visit www.extron.net



C5067
PULSAR 40 Brushless Motor



C6130
PULSAR 50 Brushless Regler
PULSAR 50 Brushless ESC



C6662
Akku EXTRON X1 - 4500-3S
Battery EXTRON X1 - 4500-3S



C6566
MASTER Flight Control 2
Flugstabilisator
Flight Stabilizer



C5374 MASTER
Fernsteuerset 2.4Ghz
Radio Set 2.4Ghz



C4995 Servo DS3012
(4 Stück erforderlich)
(4 Pcs. Required)



C5753
PI-CON Propeller 12 x 6



C4738
Akku Klettband
Battery Straps



C5896 Contest Spinner 51mm rot/red
C5895 Contest Spinner 51mm weiß/white
C5897 Contest Spinner 51mm schwarz/black



Geheimtipp! Must Have!

C6301 Schutztaschenset für Tragflächen (1 Paar)
Protective Wing bags (1 Pair)

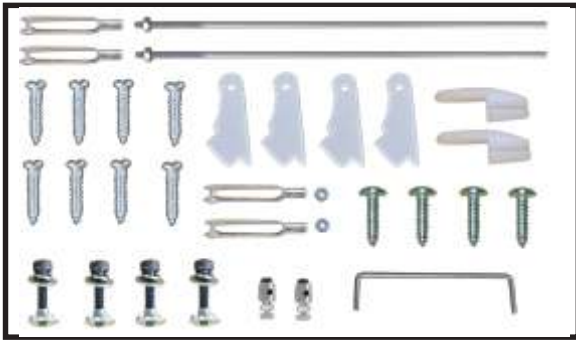

Querruder / Aileron

1. Servoeinbau / Servo Installation

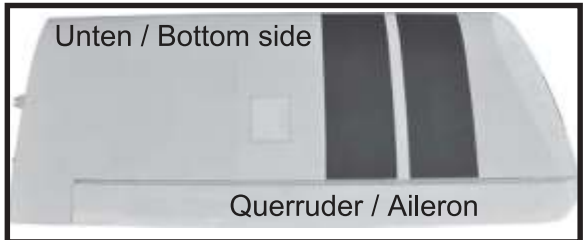
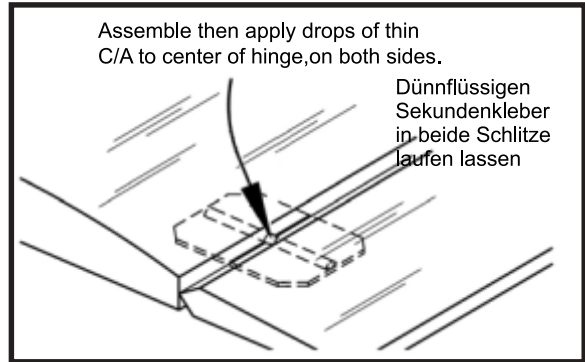
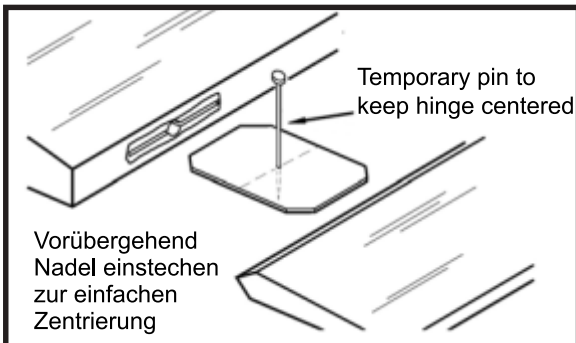
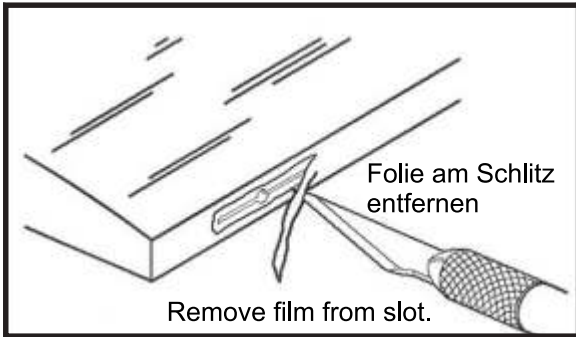
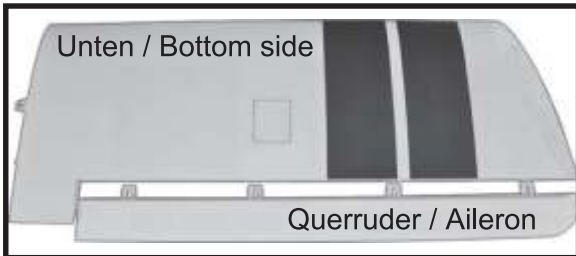

Mit einem scharfen Bastelmesser die Folie an den gezeigten Stellen vorsichtig entfernen.

□ Using a modeling knife, remove the covering at position show below.

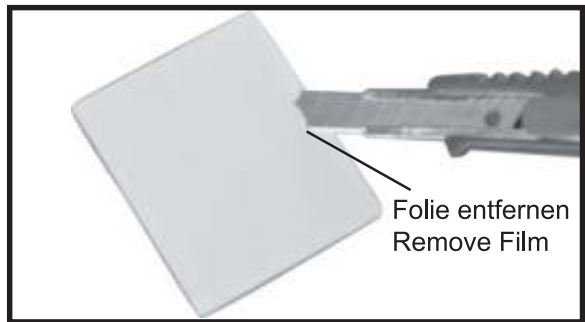
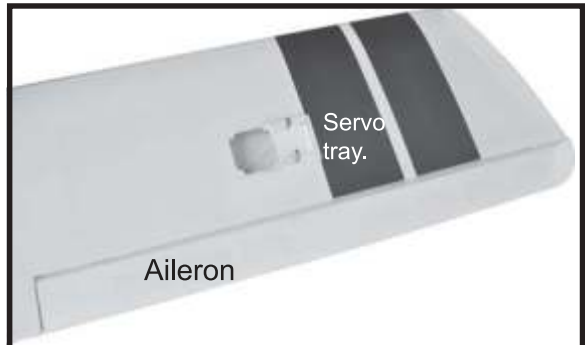

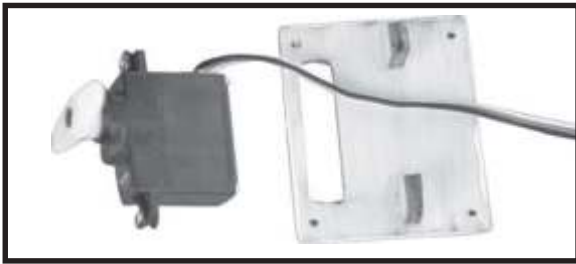

Servokabel an der Schnur mit Klebeband sichern und durch die Tragfläche ziehen

- Using the thread as a guide and tape to servo wire. Pull wire through wing.

Löcher mit 1,6mm bohren

- Drill 1,6mm pilot holes

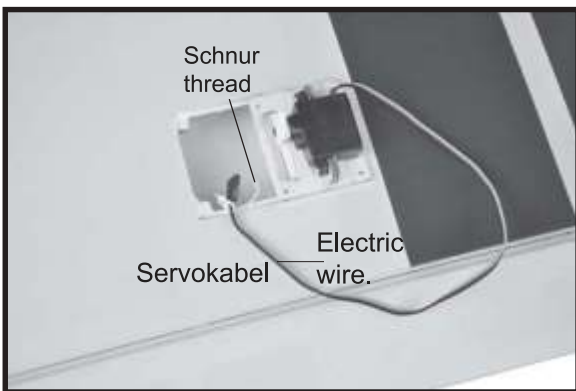

Servoabdeckung wie gezeigt installieren

- Install servo tray with aileron servo into the wing as same as picture below.

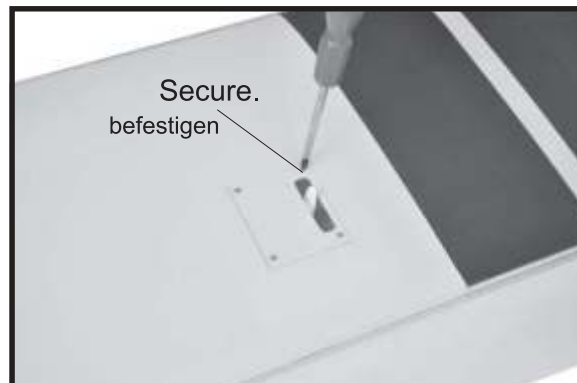
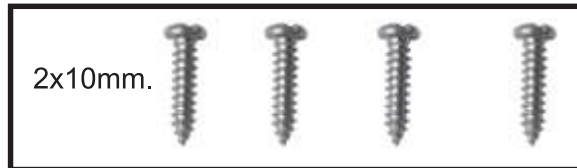

**Querruderanlenkung
AILERON CONTROL HORN.**

Anlenkhebel wie gezeigt installieren:
Install aileron control horn as shown:

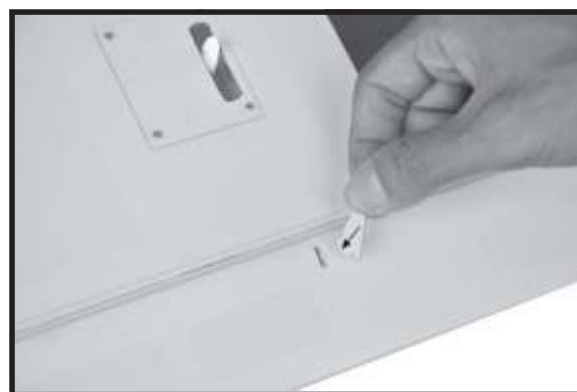
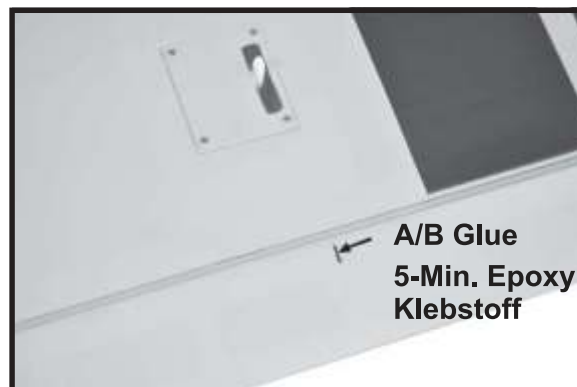

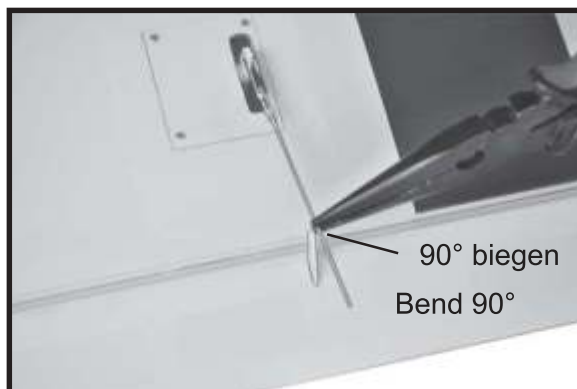
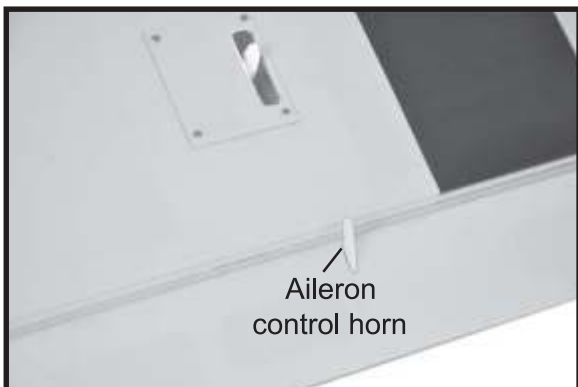

**Querruderanlenkung
Aileron Linkages**

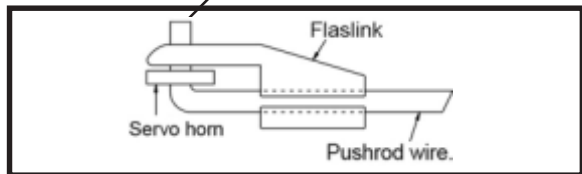
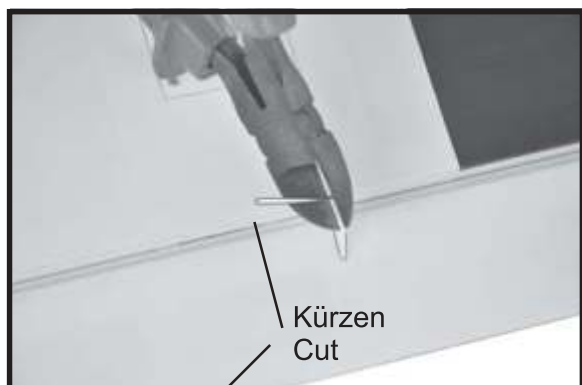
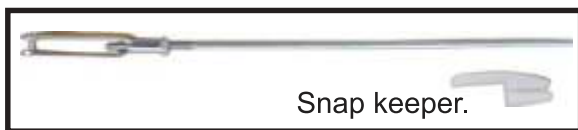
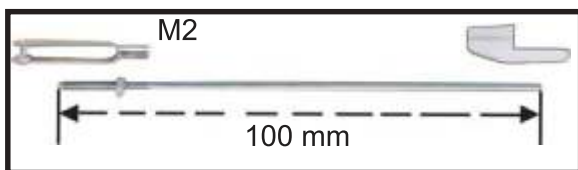

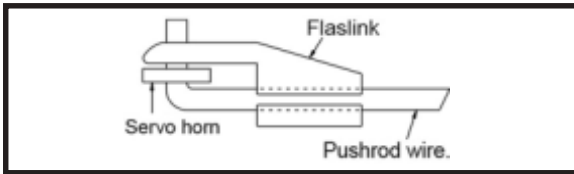

Motor Installation

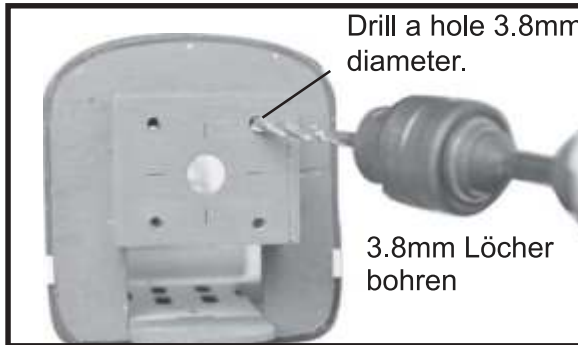

Akku und Regler / Battery and ESC

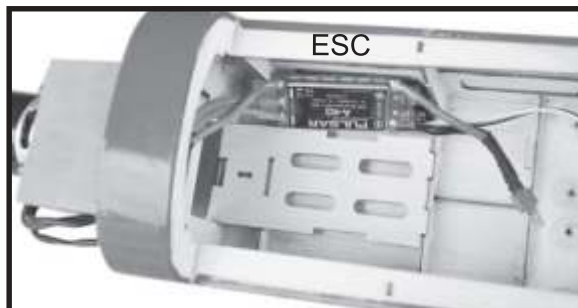



Motorhaube

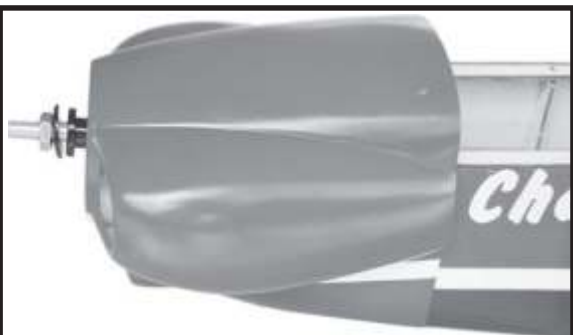

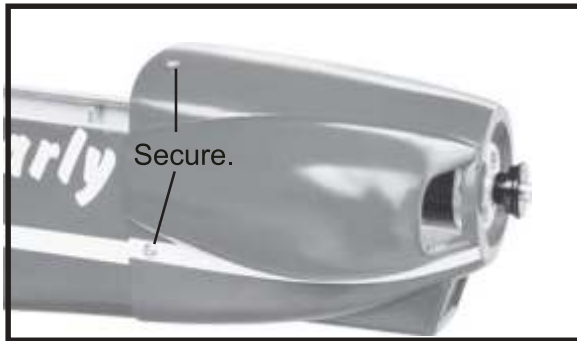
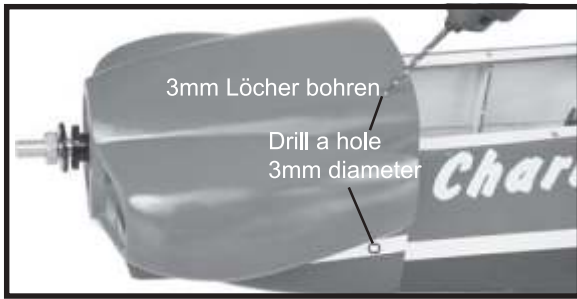

Spinner



Höhenruderservo / Elevator servo

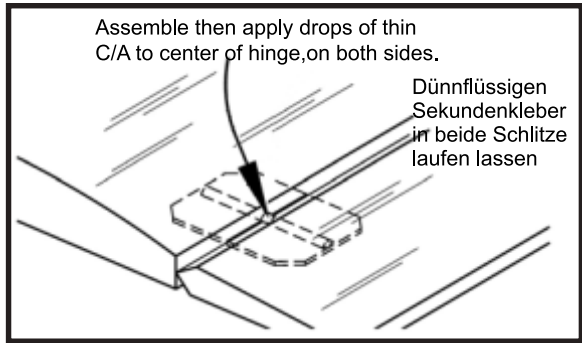
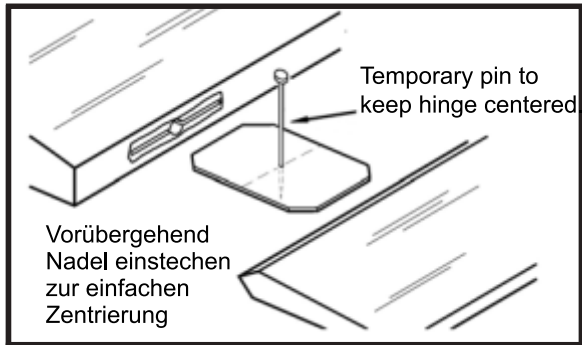
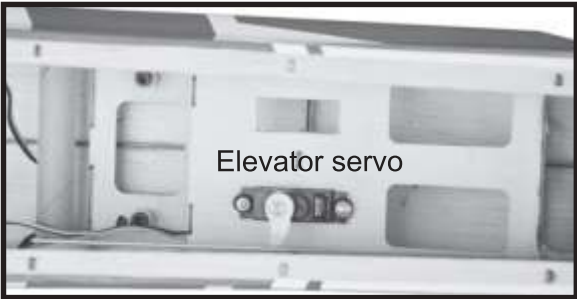

Höhenruder

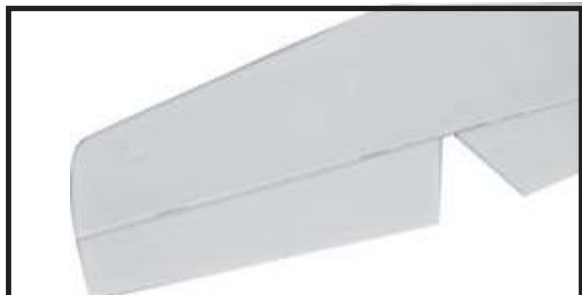
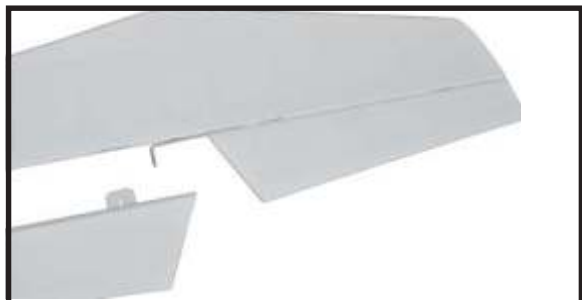
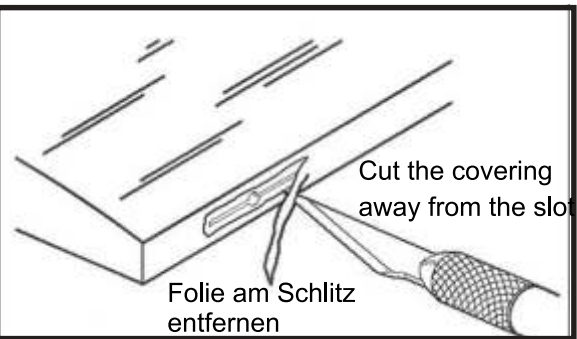
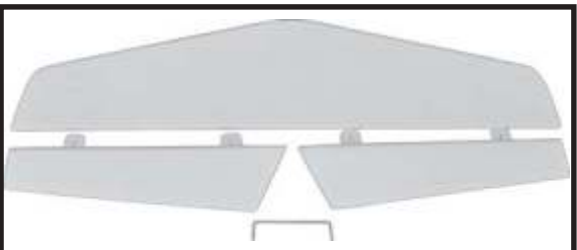
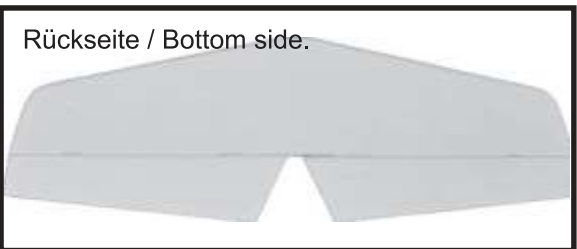

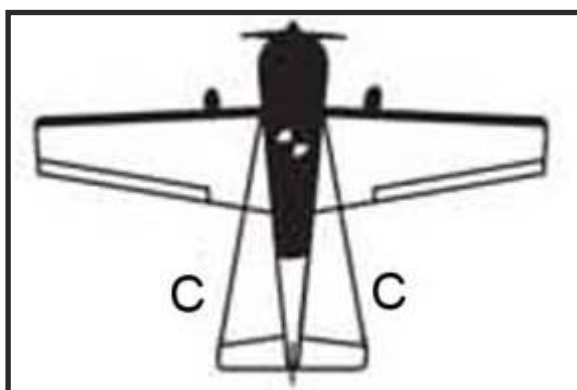
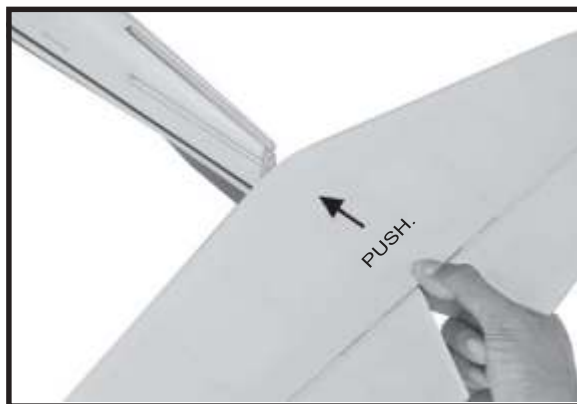
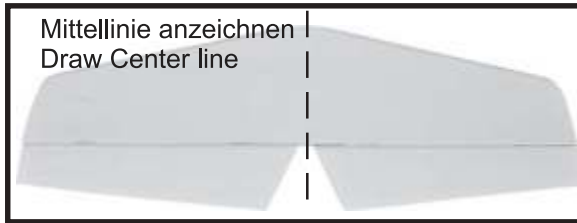

Folie an den Klebestellen vorsichtig entfernen.
ACHTUNG: Nicht ins Holz reinschneiden.
Remove covering film on glueing areas.
ATTENTION: Do not cut into the wood.

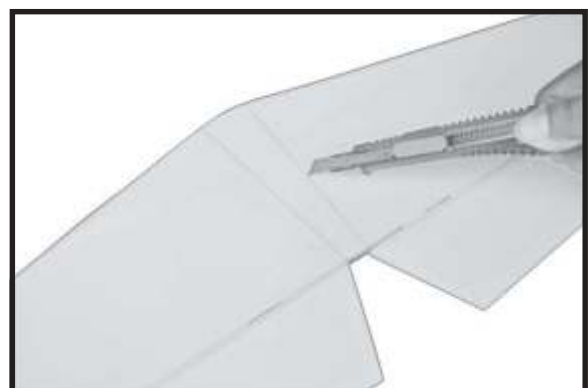

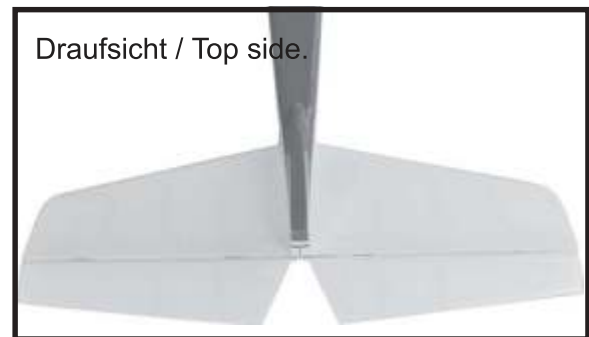
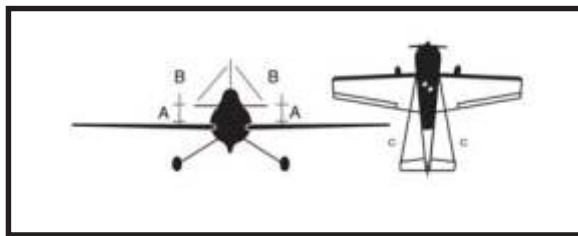
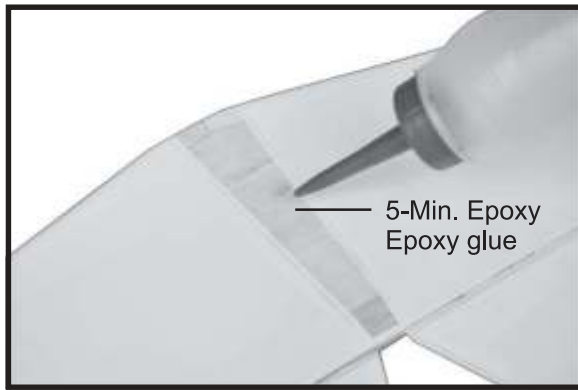

Höhenruder und Tragfläche müssen parallel zueinander ausgerichtet sein

Elevator and Main wing must be aligned parallel to each other.

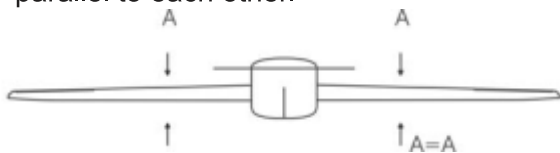

Höhenruderanlenkung / Elevator Linkage

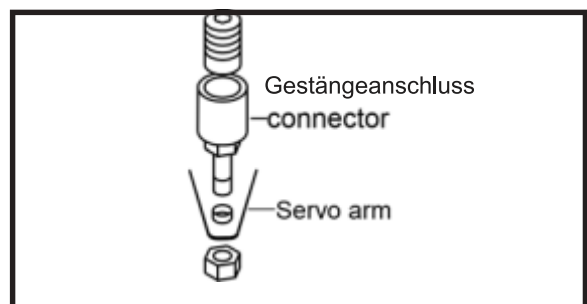
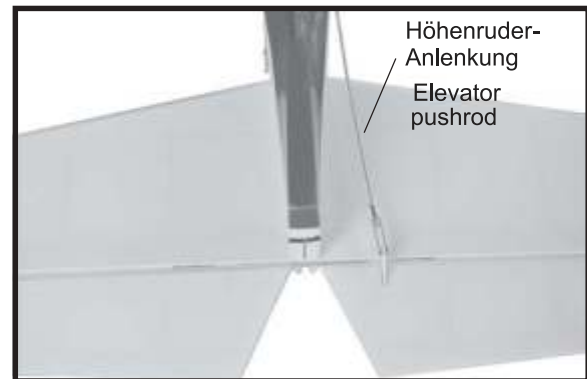
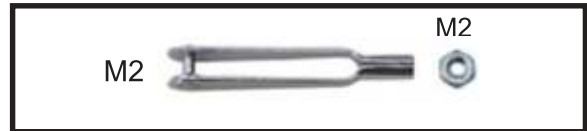
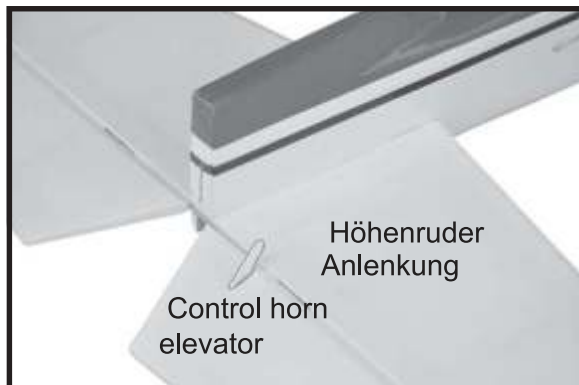
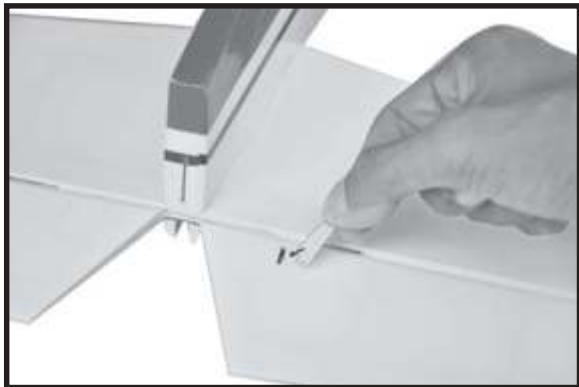

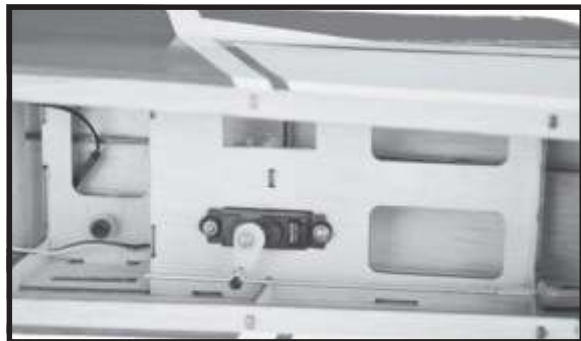

Seitenruderservo / Rudder Servo

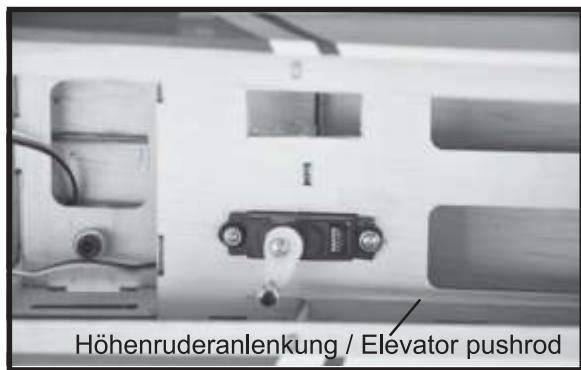
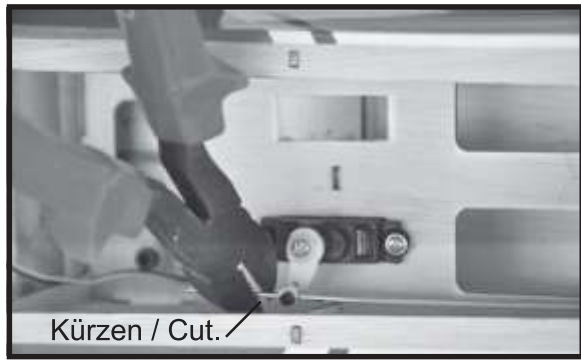
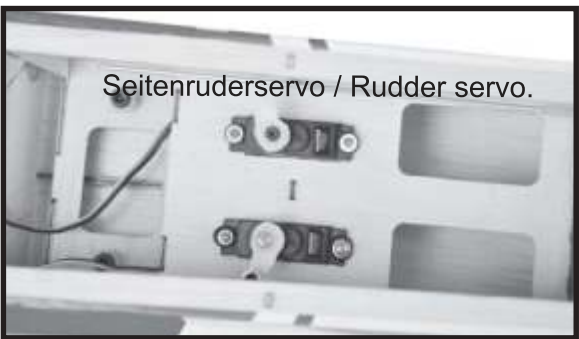
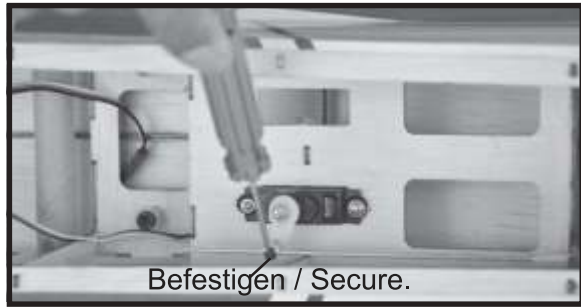

Seitenruder / Vertical Stabilizer



Folie an den Klebestellen vorsichtig entfernen.
ACHTUNG: Nicht ins Holz reinschneiden.
 Remove covering film on glueing areas.
ATTENTION: Do not cut into the wood.

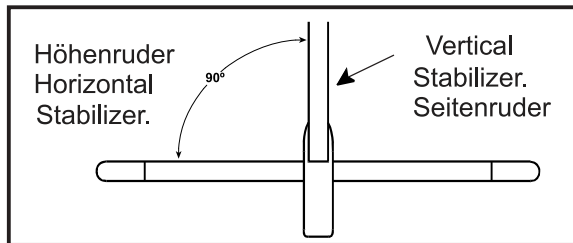
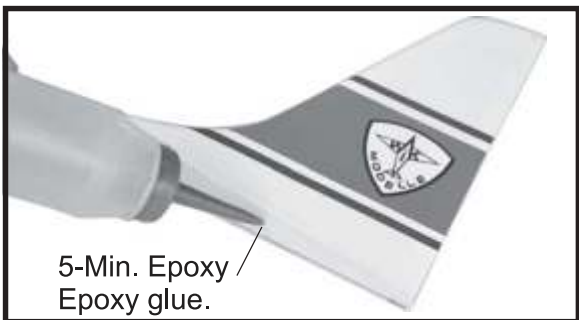

Seitenleitwerk zu Höhenruder und Tragfläche
 90° rechtwinkelig ausrichten.
 Seitenleitwerk zu Höhenruder und Tragfläche
 90° rechtwinkelig ausrichten.

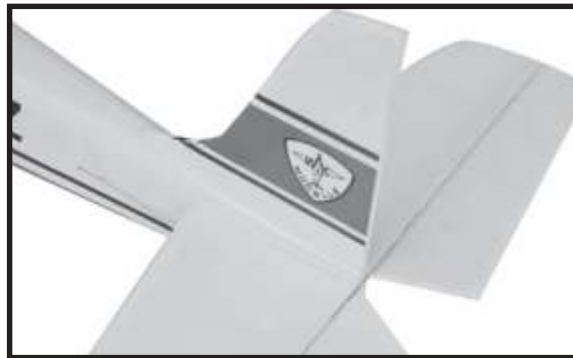

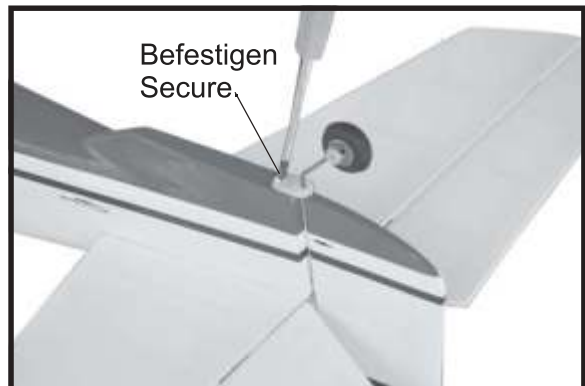
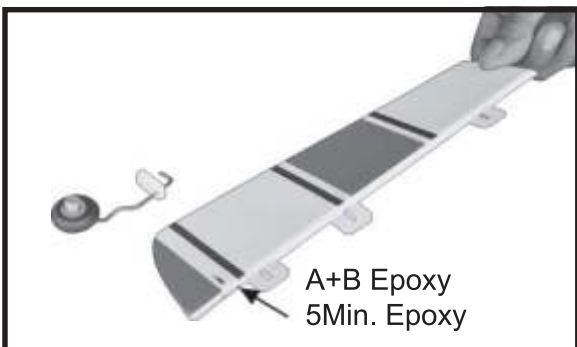



Ruderhebel Seitenruder
Control horn of Rudder.



Seitenruderanlenkung / Rudder Pushrod

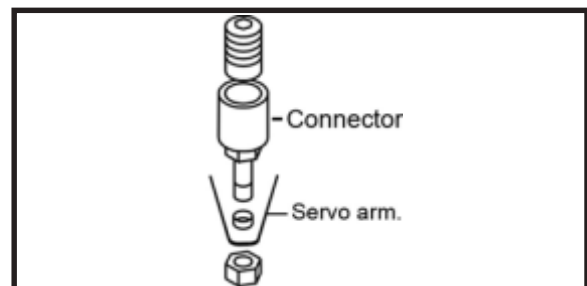
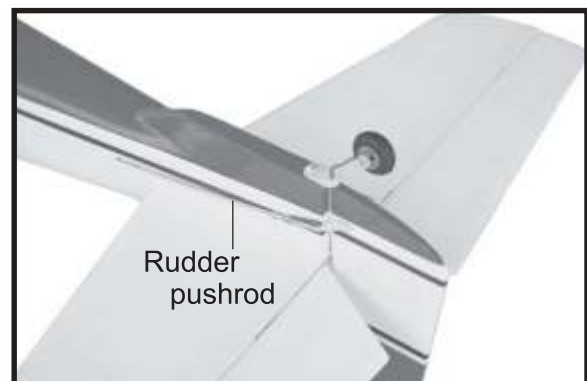
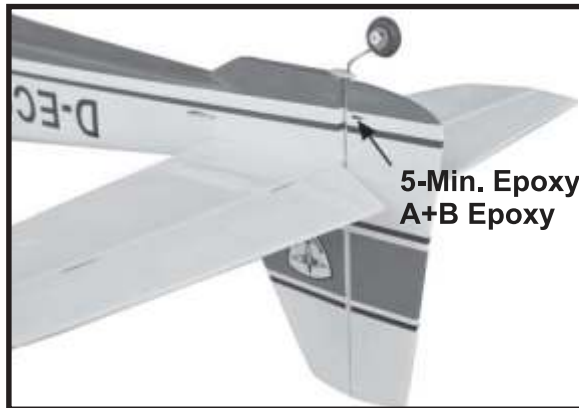

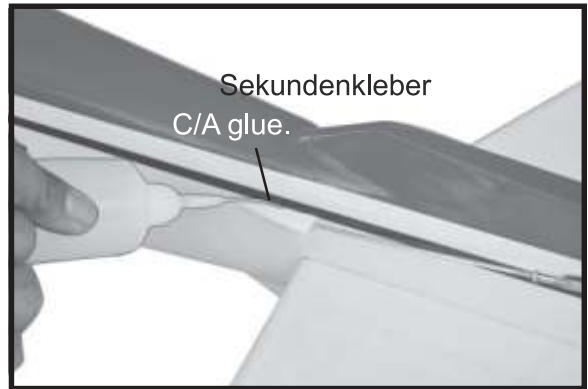
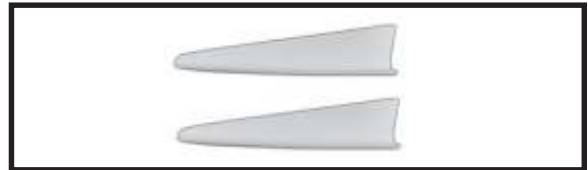
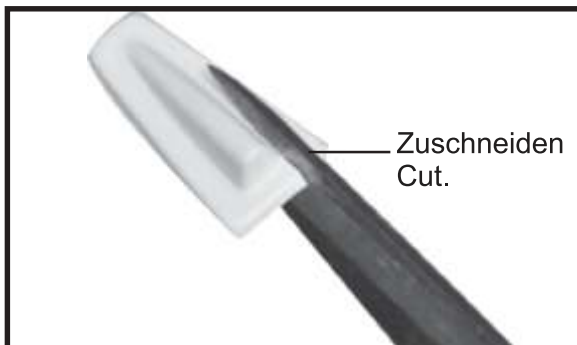
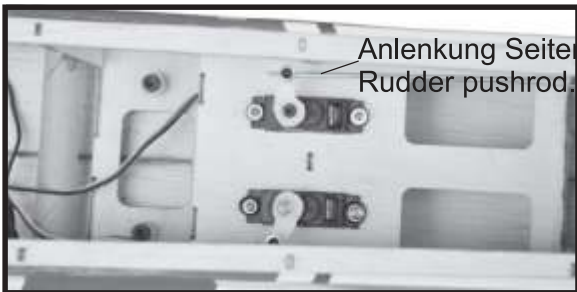
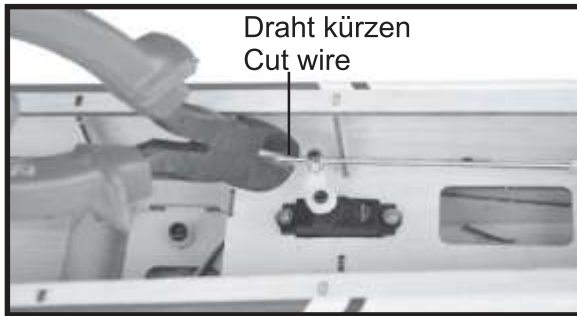
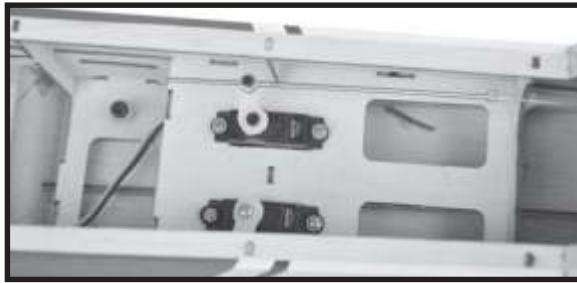

Hauptfahrwerk / Main Gear

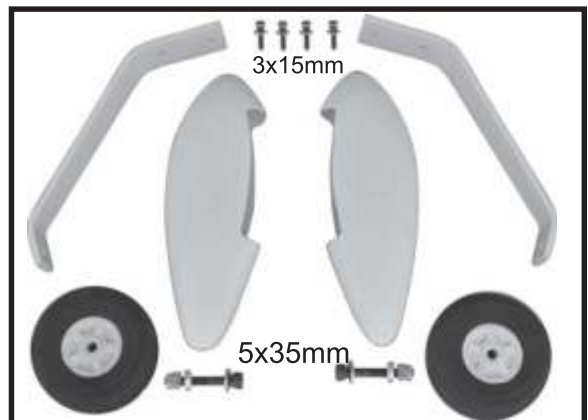

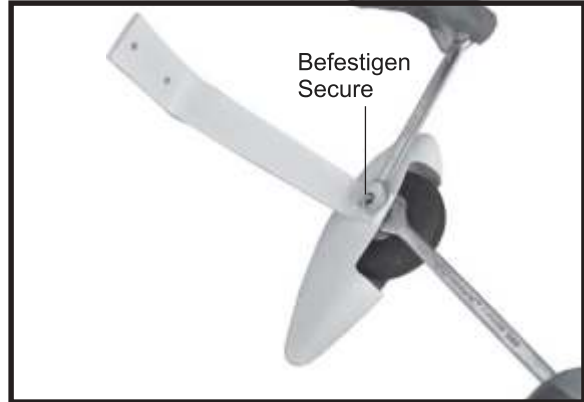
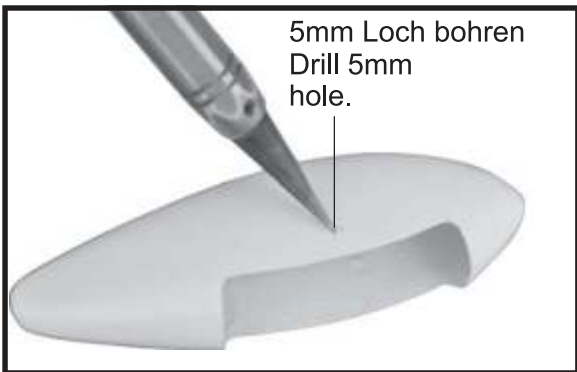
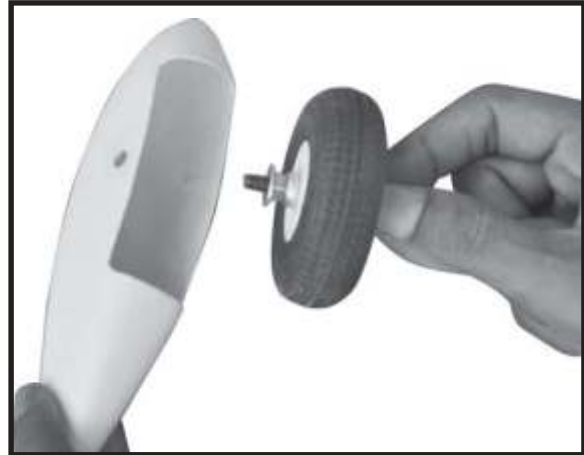

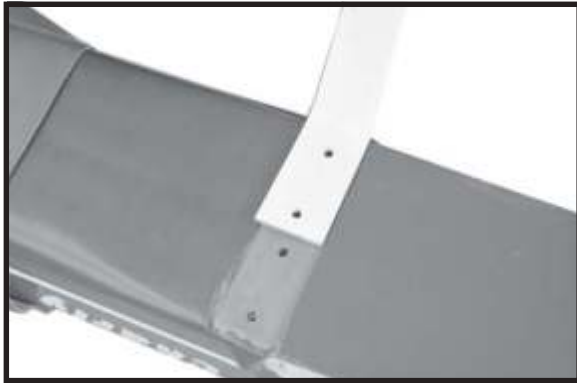

Empfängereinsatz / Receiver Installation

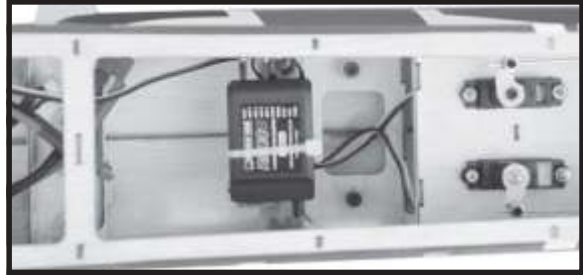

Tragflächen / Wings

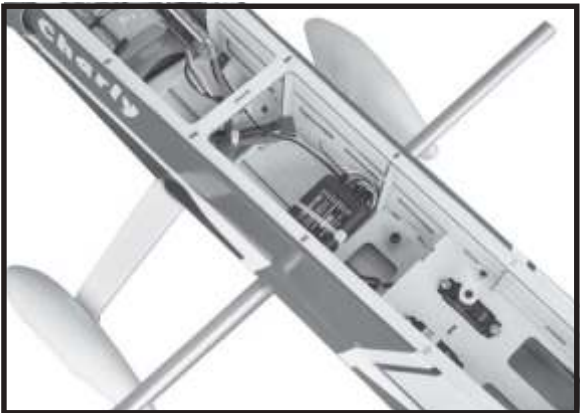
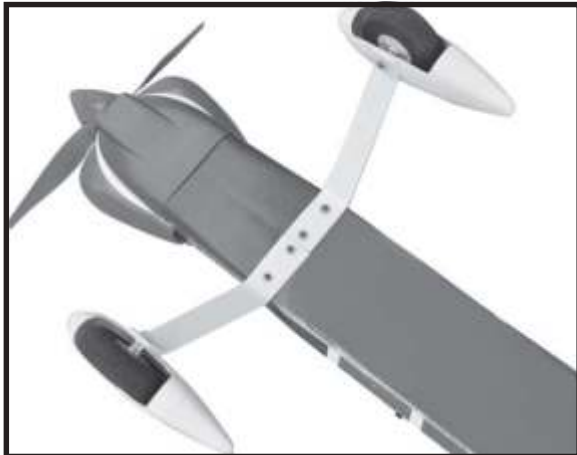
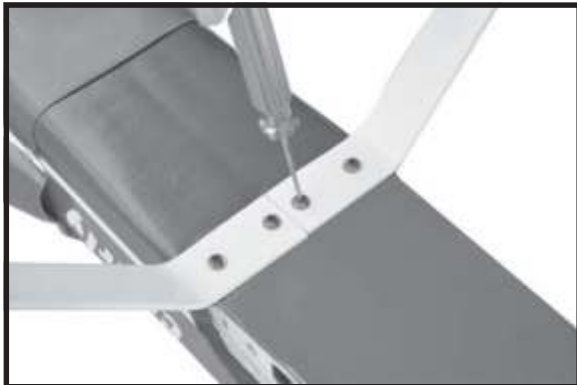
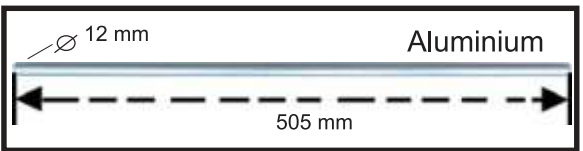

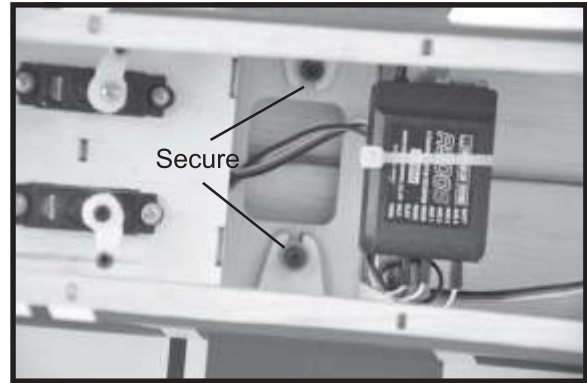
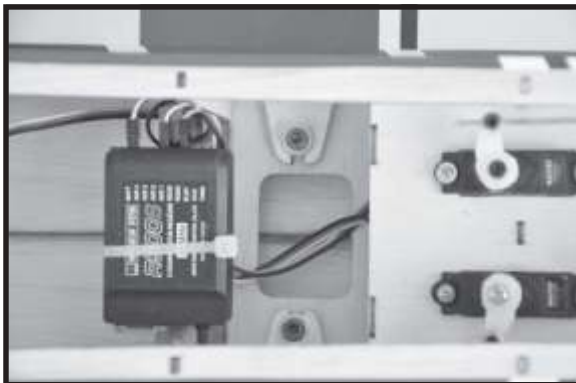
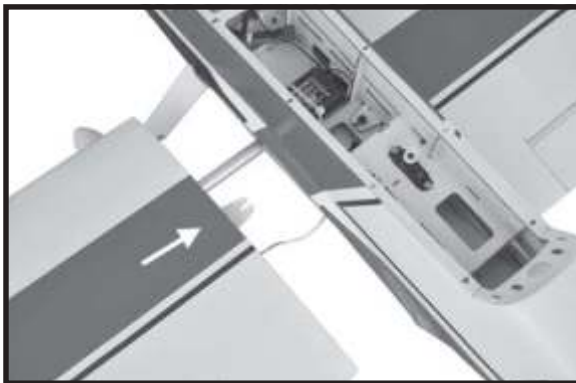
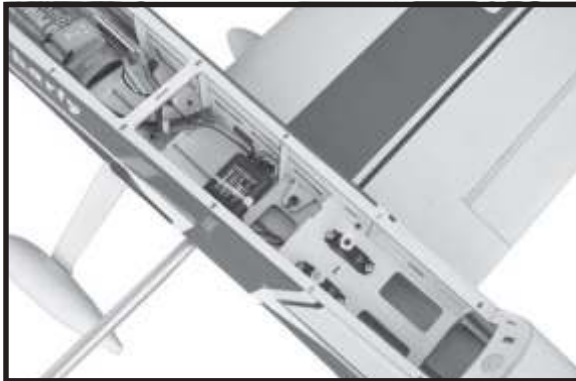
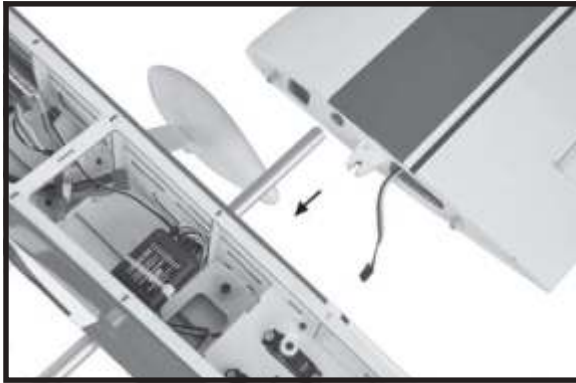

Cockpit Installation

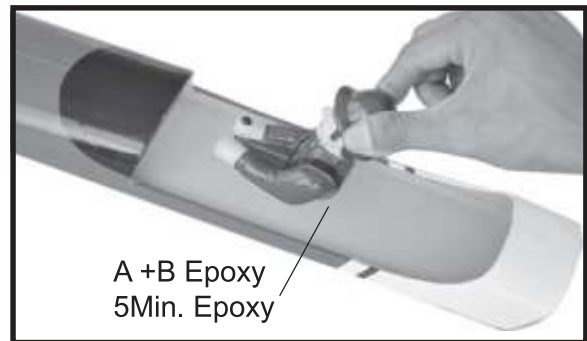

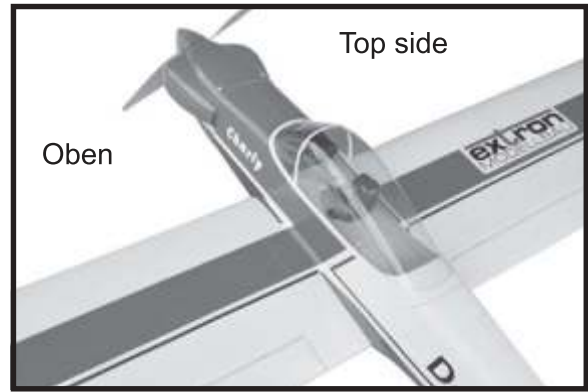
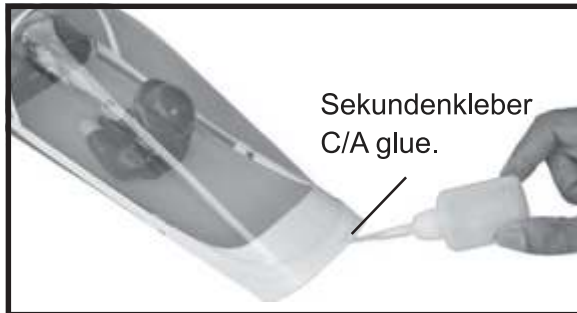
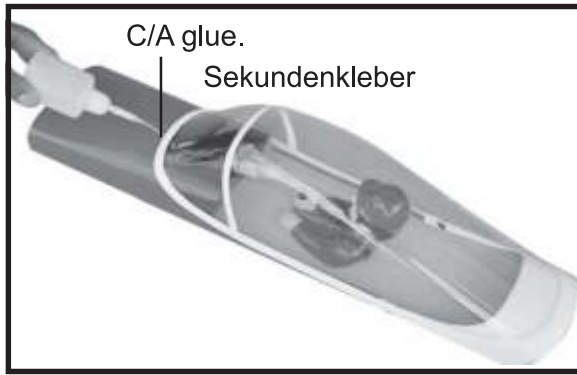

Schwerpunkt / Center of Gravity

Der ideale Schwerpunkt befindet sich 85 -90mm von der Tragflächenvorderkante aus gemessen.
 The ideal Center of Gravity (C.G.) is located 85 -90mm behind the leading edge.

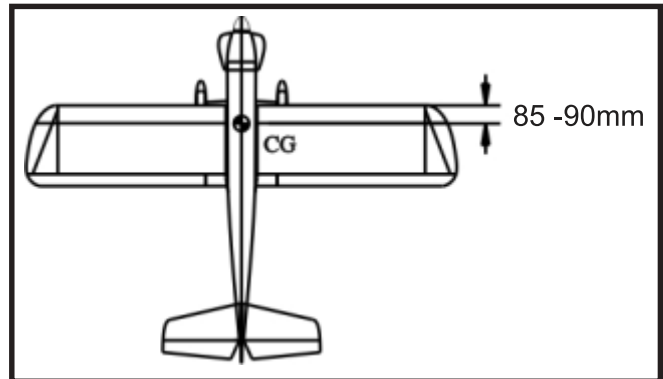

Ruderausschläge / Control Throws

- Querruder / Ailerons : 10mm + / -
- Höhenruder / Elevator : 15mm + / -
- Seitenruder / Rudder : 15mm + / -

